



# **SULFUR SENTRY HYDROGEN SULFIDE ANALYZER OPERATION AND INSTALLATION MANUAL**

August 2009

## **Envent Engineering Ltd.**

**Bay E 7060 Farrell Road S.E.**

**Calgary, Alberta, Canada**

**T2H 0T2**

**Phone: 403 253 4012**

**Fax: 403 253 4016**

**info@envent-eng.com**

**[www.envent-eng.com](http://www.envent-eng.com)**





## Table of Contents

<b>Introduction</b>	<b>1</b>
<b>Specifications</b>	<b>1</b>
<b>Component Location</b>	<b>2</b>
<b>Principle of Operation</b>	<b>3</b>
<b>Installation and Start-up</b>	<b>4</b>
<b>Sample Point Selection</b>	<b>4</b>
<b>Sample Volume and Flow Rate</b>	<b>4</b>
<b>Sample Conditioning</b>	<b>5</b>
<b>Installation Procedure</b>	<b>5</b>
<b>Operator Interface</b>	<b>7</b>
<b>Calibration</b>	<b>7</b>
<b>Calibration Procedure</b>	<b>7</b>
<b>Tape Replacement Procedure</b>	<b>9</b>
<b>Maintenance &amp; Trouble Shooting</b>	<b>10</b>
<b>Sensor Standardization Procedure</b>	<b>11</b>
<b>Sample System Cleaning Procedure</b>	<b>12</b>
<b>Sample Chamber Assembly Drawing</b>	<b>12</b>
<b>Factory Calibration Sheet</b>	

*PDF copies of the Manual are available at <http://www.envent-eng.com>  
The latest version of the software can be found on the contact page at  
<http://www.envent-eng.com>*



## Introduction

The Sulfur Sentry H<sub>2</sub>S analyzer designed for temporary monitoring of H<sub>2</sub>S in natural gas pipelines. The analyzer will operate from an internal battery for over 12 hours. The H<sub>2</sub>S concentration is archived internally in non-volatile memory for later retrieval. The archive data can be exported to a spreadsheet for analysis and storage.

## Specifications

<b>Measurement method</b>	ASTM D4084 - 07 : Standard Test Method for Analysis of Hydrogen Sulfide in Gaseous Fuels (Lead Acetate Reaction Rate Method)
<b>Ambient Temperature</b>	0-50 Deg C° (standard) consult factory for other requirements
<b>Power</b>	0 to 90% humidity (non-condensing) 12 vdc internal battery @ less than 3 watts for >12 hour operation, 120 vac wall charger and 12 volt vehicle charge cables included
<b>Electrical Certification</b>	General area classification Pending
<b>Output Ranges</b>	Ranges between 0-100 parts per billion to 0-100 ppm are standard.
<b>Response time</b>	20 sec to 90% of step change
<b>Accuracy</b>	1.5% of reading
<b>Display</b>	2x16 character LCD with back lighting Menu is scrolled by internal button
<b>Optional Equipment</b>	Solar power to extend battery operation



- Sample Inlet (1500 psi max)
- Sample Gas Outlet (Apply no backpressure)
- Speed Loop Outlet

Sample Connections **(Remove tubing caps before applying pressure)**

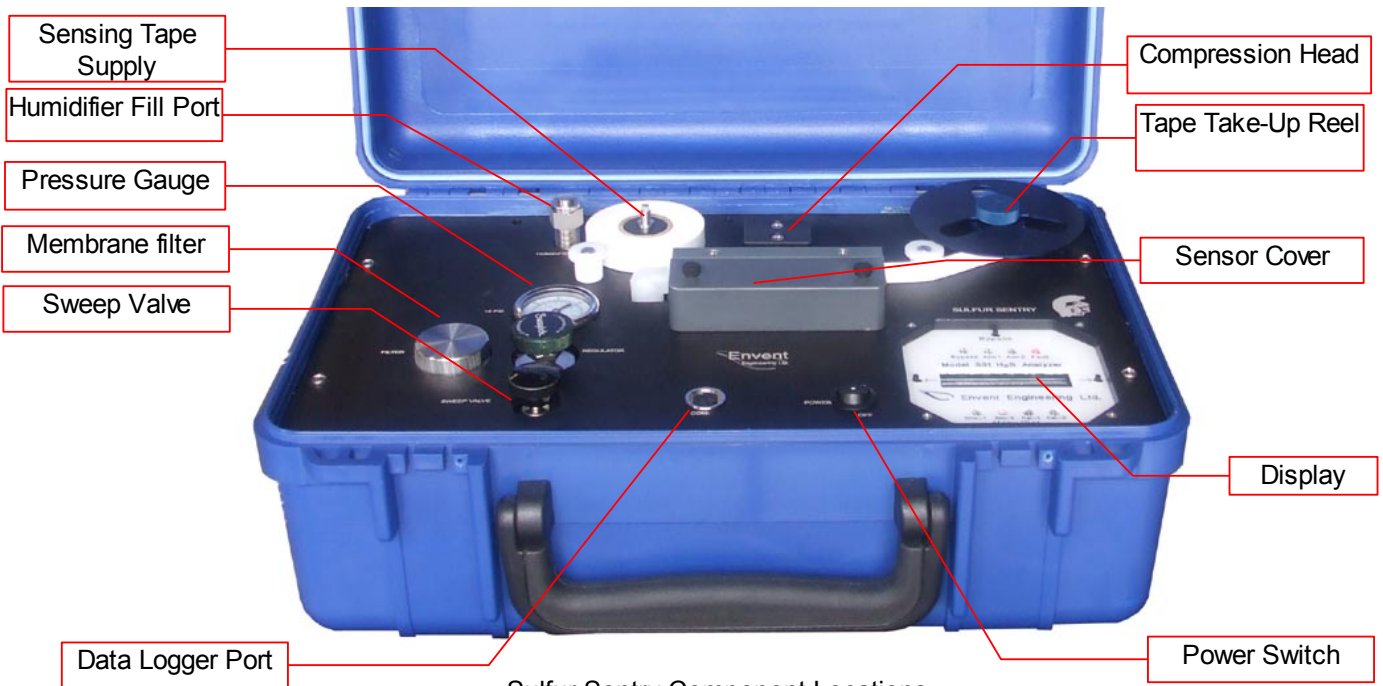

Sulfur Sentry Component Locations

## Principle of Operation

The Envent Engineering Ltd. Sulfur Sentry uses ASTM D4084 - 07 : Standard Test Method for Analysis of Hydrogen Sulfide in Gaseous Fuels (Lead Acetate Reaction Rate Method).

When hydrogen sulfide contacts the lead acetate treated tape a brown stain appears. The Sulfur Sentry electronics measure the rate of darkening over time and calculates the hydrogen sulfide concentration.

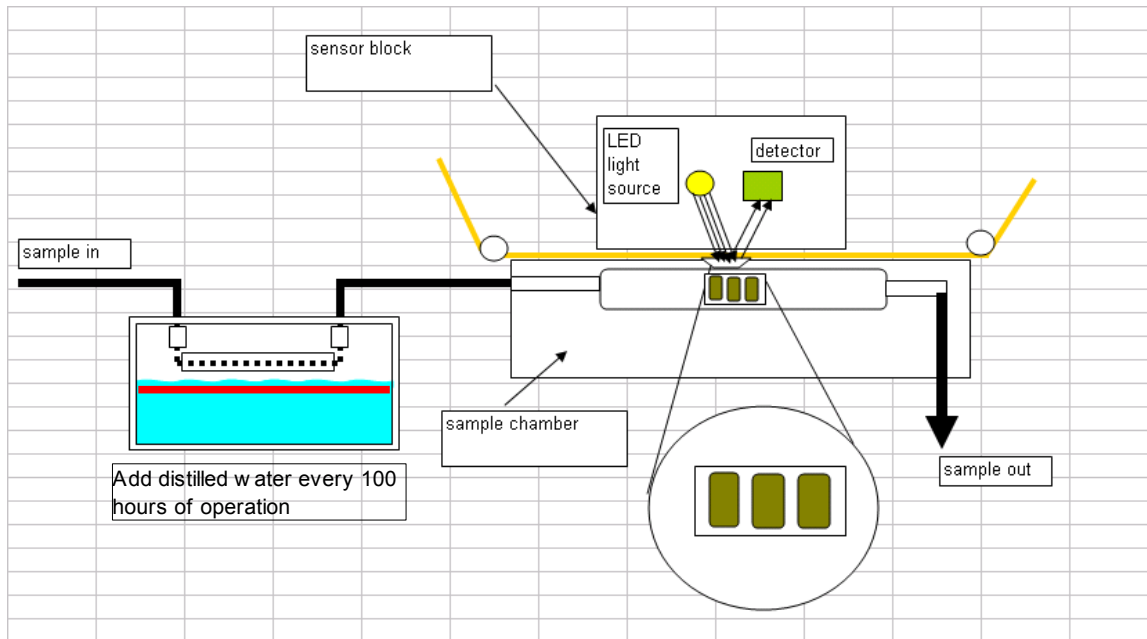
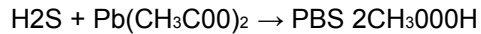

**Analyzer Diagram**

A flow and pressure regulated filtered sample passes through a membrane humidifier and into the sample chamber. A window in the sample chamber allows the gas to come in contact with the tape creating a concentration dependent stain when hydrogen sulfide is present. In high concentration applications (over 20 ppm), there may be a restricting aperture behind the window. Various sizes of apertures match different measurement ranges.

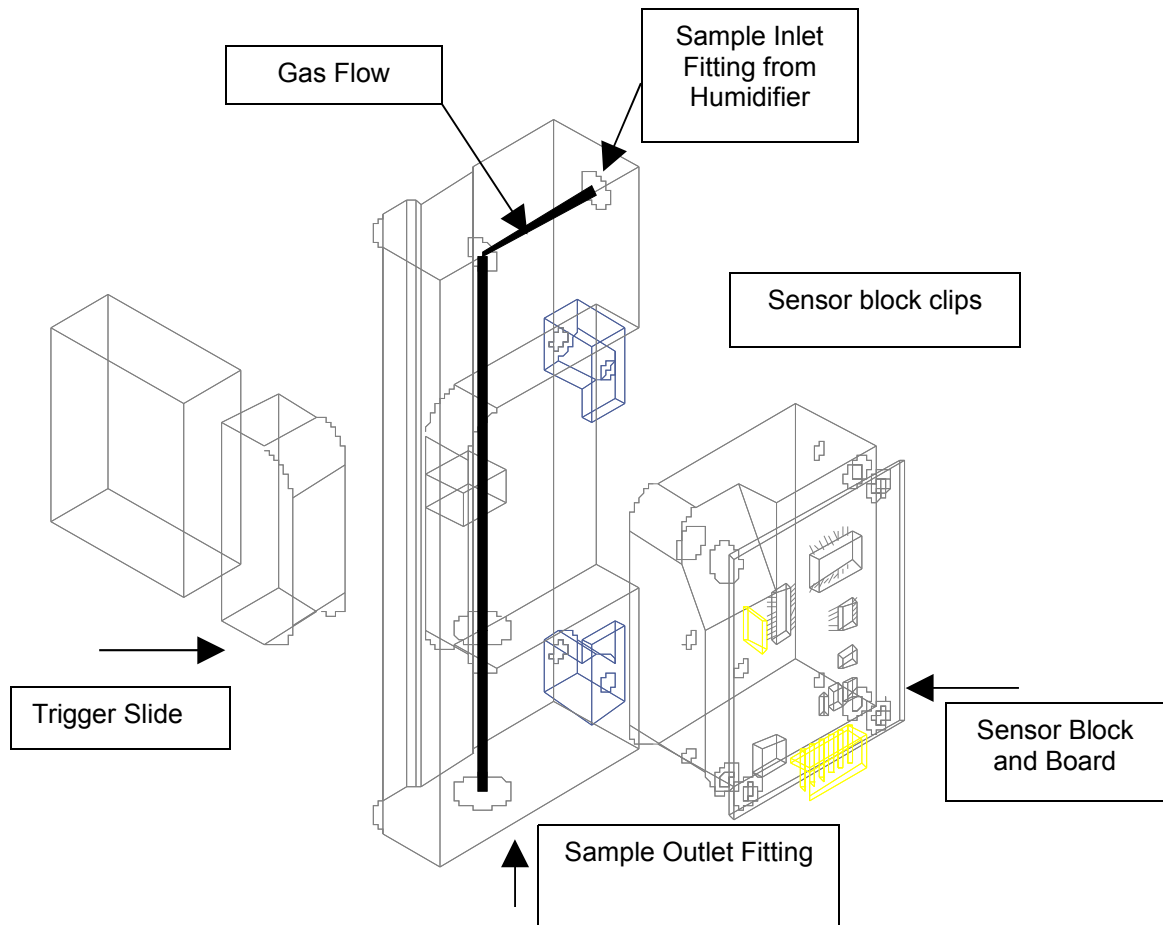

**Figure 2: Sample Chamber and parts**

### Installation and Start-up

Your Sulfur Sentry analyzer was configured, functionally tested and calibrated at the factory. All test and calibration data is documented in the factory calibration report at the end of the manual.

**The analyzer should be located in an area in which it is not exposed to vibration and excessive pressure and temperature variations. The Sulfur Sentry is designed for general area locations. Ensure that the area can be safely de-classified to non-hazardous before operating.**

### Sample Point Selection

The sample to the analyzer must be representative of the process stream and should be taken from a point as close as possible to the analyzer to avoid lag times and sample degradation in the tubing. An optional Genie GPR probe regulator may be included in the materials packed with the analyzer. A  $\frac{3}{4}$  weldolet is required for installation. The probe must be installed vertically ensuring that the sample is drawn from the middle 1/3 of the pipeline. The function of this probe is to ensure a clean dry sample to the analyzer and to reduce the pressure of the sample. The lower pressure will decrease the response time of the analyzer. Refer to the probe installation instructions packed with the probe.

**The Genie probe regulator is highly effective and is recommended for all analyzer installations.**

### Sample Volume and Flow Rate

The sample should be supplied to the analyzer at 10-15 psig. The flow is internally controlled to 100-200 cc/m. A bypass sweep is recommended to reduce sample lag time in the sample line if it is at high pressure or longer than 15 feet. For best performance it is advisable to reduce the pressure at the sample. Sample line tubing is generally 1/4" 316 stainless steel. 1/8" stainless steel tubing can be used if response time is critical.

## Sample Conditioning Systems

The function of the sample system is to regulate and filter particulates or free liquids from the sample. Consideration must be taken of upset conditions as well as normal conditions when designing the sample system. The figure below shows the typical sample system used for the Sulfur Sentry.

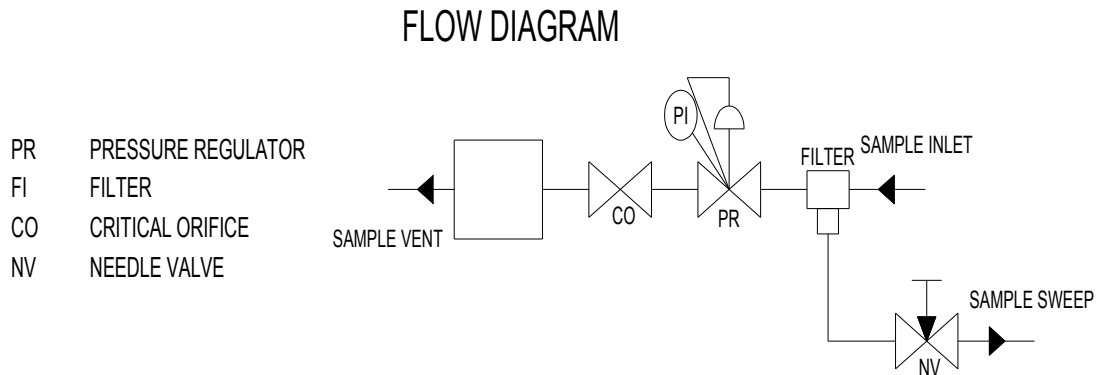

### Standard Coalescing & Regulator Sample System

This system consists of a 1500 psig membrane inlet filter and a 3000 psig inlet regulator. The drain valve on the filter is normally left slightly open to drain any liquids that may collect and to provide a sample sweep to reduce lag time in the sample piping.

### Installation Procedure

1. Unpack the analyzer and Check for Damage.
2. Select an installation location that is close to the sample point.
3. Tube the sample inlet, sweep and vent lines to the analyzer. 1/4" 316 stainless steel tubing is recommended for the sample tubing. 1/8" 316 stainless steel tubing can also be used if the response time of the analyzer is of particular concern. All fittings in the sample and vent lines must be 316 stainless steel (Swagelock or equivalent). The vent line should be tubed in 3/8" stainless steel or plastic tubing to a maximum of 6 feet. The tubing should be installed with a slight downward slope and should be as short as possible. The vent line must be tubed to atmospheric pressure and **cannot** be connected to a flare line. Avoid connecting multiple vents to the same line.
4. Ensure the analyzer has a sufficient quantity of sensing tape and distilled water in the humidifier. A sensing tape and one litre of distilled water acid were provided with the analyzer.
5. With the sample pressure turned off. Apply power to the analyzer. The display will illuminate and the sensing tape will advance.
6. Press the menu button until mv is displayed. Check that the mv reading is 1000 mv +/- 100 mv.
7. The sample gas pressure can be applied.

8. Open the sweep valve slightly and adjust pressure regulator to 15 psig.
9. Allow ten minutes for the analyzer to stabilize. The analyzer calibration can be verified if calibration gas is available (refer to the calibration section). If no calibration gas is available, the analyzer may be operated using the factory calibration settings until calibration gas is available.

### **Sample Lag Time vs Tubing Size**

<u>Tube size</u>	<u>Tube Gauge</u>	<u>ID inches</u>	<u>ID cm</u>	<u>Flow SCFH</u>	<u>Flow Std. cc/ min</u>	<u>Pressure PSIA</u>	<u>Time Lag per 100ft Minutes</u>	<u>Time Lag per 100ft Seconds</u>
3/8	20	0.319	0.8103	5	2359	800	36.3	2178
3/8	20	0.319	0.81	5	2359	200	9.07	544
3/8	20	0.319	0.81	5	2359	50	2.27	136
1/4	20	0.18	0.459	5	2359	800	11.69	701
1/4	20	0.18	0.46	5	2359	200	2.92	175
1/4	20	0.181	0.46	5	2359	50	0.73	44
1/8	24	0.08	0.205	5	2359	800	2.34	140
1/8	24	0.08	0.21	5	2359	200	0.59	35
1/8	24	0.081	0.21	5	2359	50	0.15	9

## Operator Interface

The Sulfur Sentry is configured from the front panel. A computer interface is also available and described in a separate section supplied with the software.

### Bypass and Menu Buttons

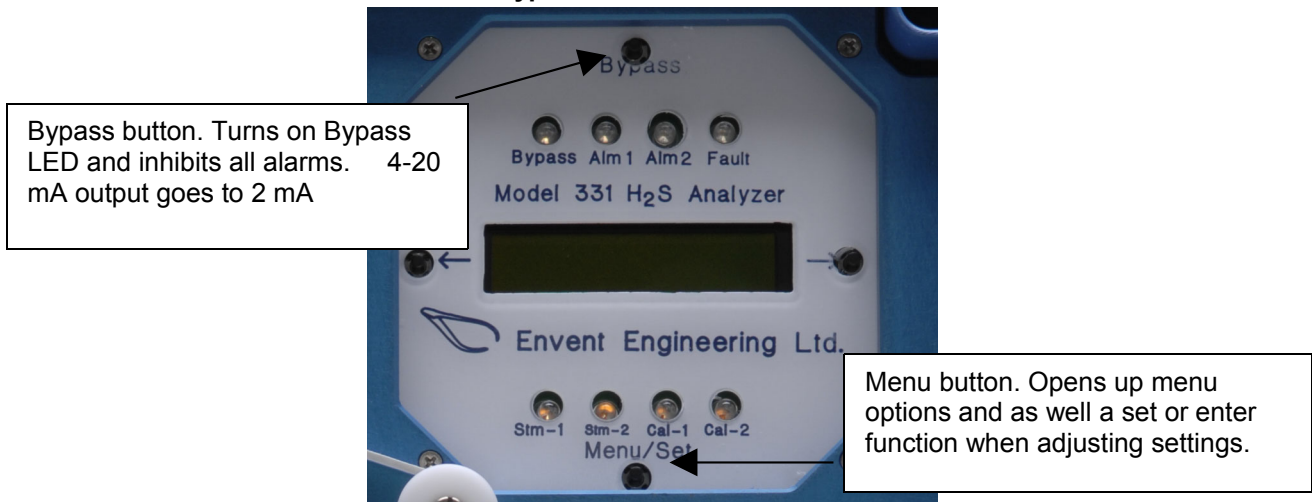

### Menu buttons

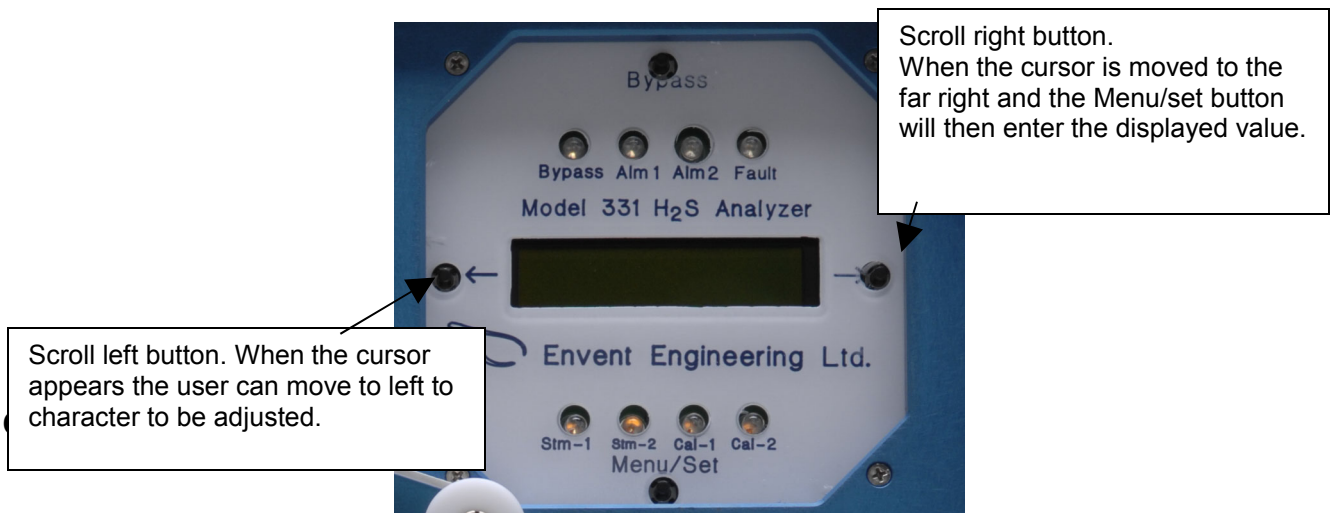

## Power Supply

The analyzer operates from 12 volt internal Gel-Cell batteries for more than 12 hours when fully charged. The battery voltage can be observed by scrolling the menu key until VBAT is displayed. 13.5 volts is fully charged and 11.5 volts is fully discharged. The analyzer fault led will illuminate at 11.5 volts and LOW BAT will appear in the current alarm menu. An automatic wall charger is included to charge the batteries when ac power is available. The supplied vehicle cable can be used to charge the analyzer from a vehicle.

## Calibration

The calibration of the Sulfur Sentry was set at the factory. The gain setting can be found in the factory calibration section at the end of the manual.

## Calibration Procedure

Ensure a suitable calibration gas and a clean stainless steel regulator with the correct CGA fitting is available. Check that the regulator is rated for calibration cylinder pressure.

The recommended calibration gas is hydrogen sulfide in a balance of nitrogen certified and analyzed. Calibration gas concentration should be approximately 2/3 of the full scale range of the analyzer or at the shut in point of the facility be monitored. Check the expiry date printed on the certification before using.

Note: The menu is operated with the push buttons on the Sulfur Sentry analyzer. The top line of the display will display the hydrogen sulfide concentration in ppm; the lower line can be set to display the hydrogen sulfide concentration in grains or various diagnostic values.

Turn off the sample flow

Ensure an adequate supply of tape and acetic acid

Push the menu button Menu/Set button until Mtr Run is displayed.

Push the right arrow button to manually advance the tape

Press the Menu/Set button until mv is displayed

Verify that the mv reading is 1000 mv +/- 100 mv with white tape in front of the sample chamber

If the mv reading is less than 900 mv or greater than 1100 mv, ensure the sample chamber is clean and the tape is free from brown stain.

If the mv reading from the sensor is between 900 mv and 1100 mv, proceed to the next step, otherwise. Remove the sensor block cover. Press the small pushbutton located on the lower side next to the wire connector. The sensor block will enter a re-zero procedure indicated by a red led. When the re-zero procedure is complete the green led will light. Re-check the mv reading on white tape.

Turn on the calibration gas flow, set the calibration gas pressure to 15 psig

Allow the analyzer to stabilize for 10 to 15 minutes.

Press the Menu/Set pushbutton until Gain is displayed.

Adjust the gain setting until the analyzer reads the correct concentration.

The new gain can be calculated as follows

$$\frac{\text{Cal Gas Concentration}}{\text{Current Reading}} \times \text{Current Gain} = \text{New Gain}$$

The gain is adjusted by pressing the right and left arrows until the cursor is under the number you wish to change.

The number can be adjusted by pressing the Menu/Set pushbutton. It will increase until 9, then cycle back through 0.

The new gain can be saved by pressing the right arrow until "Saved" appears or discarded by pressing the left arrow until "Cancel" appears.

Allow the analyzer to complete 2 new cycles with the new gain setting. Verify the reading matches the calibration cylinder analysis. Compare the new gain value with the gain specified in the factory calibration sheet. A gain significantly different from the factory gain may indicate a problem with the analyzer.

Remove the calibration gas.

Re-connect the sample gas.

Allow the analyzer to return to a no-alarm condition

Remove the analyzer from bypass

Calibration is complete

# Tape Replacement

## Tape Change Procedure

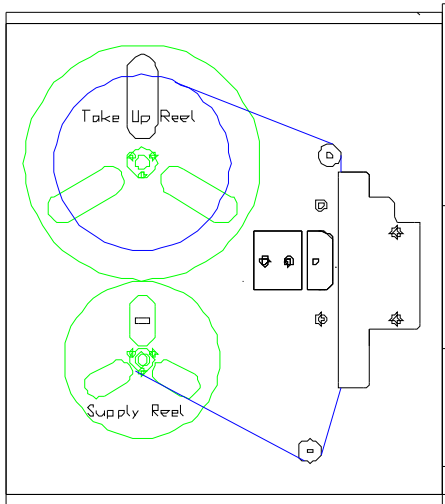

Step 1: Place analyzer in **BYPASS**

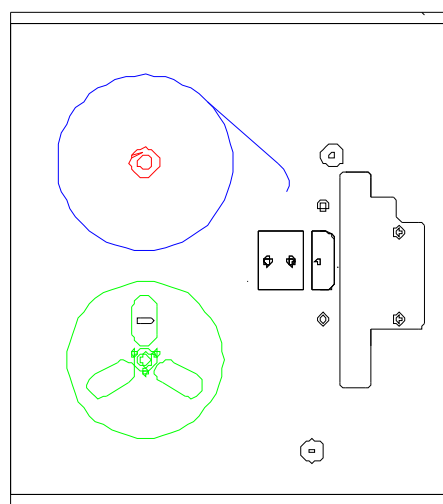

Step 2: Remove Reel covers  
Step 3: Discard old Tape

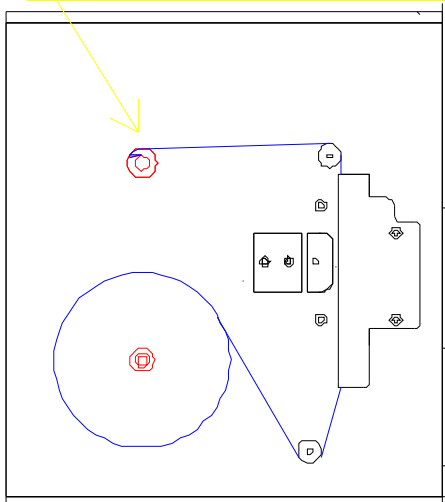
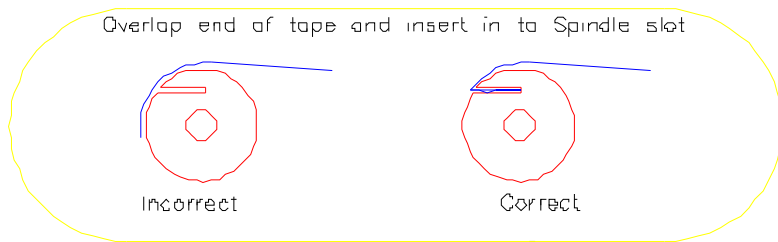

Step 4: Install new tape on Supply Reel  
Step 5: Run tape through to a Take Up spindel

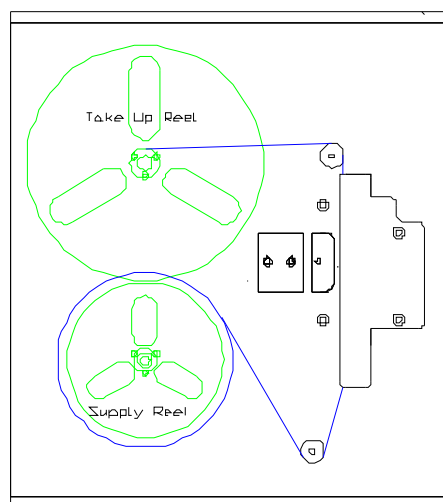

Step 6: Re-attach Reel Covers  
Step 7: From Display do a MTR Run.  
Step 8: Take analyzer out of **BYPASS**

## Maintenance & Trouble Shooting

### Monthly Check-up

Your analyzer will provide reliable service with very little attention. If the analyzer is kept clean there should be no requirement to recalibrate from factory gain settings. However, a weekly check-up will ensure that the analyzer is operating to specifications. Check that the tape take-up and feed reels are tight and flow meters are free of liquid or particulate contamination. Replace the inlet filter as required.

### Trouble Shooting

Problem	Possible reasons	Possible Solution
Erratic hydrogen sulfide Readings	a. Trigger slide not seated properly	Ensure trigger slide is seated in the groove of the sample chamber
	b. Pressure in building moving up and down from fan, exhaust or wind.	Relocate sample vent
	c. Sample vent either blocked or frozen	Vent should be 1/2" tubing on a downward slope.
	d. Liquid carry over in sample system	Sample system requires cleaning. Refer to Cleaning procedures.
	e. Regulator not maintaining 15 psig	Pre-regulation to 50 psig of sample at sample point. Possible regulator requires repair or replacement
	f. Analog Input 2 jumper removed.	Re-install jumper in Analog Input across (+4-20 & -4-20)
	g. Sensor block fault	Re-zero Sensor block. Refer to Sensor Re-zero procedure.
	h. Contaminants in sample chamber	Check and replace filter if required. Clean sample chamber. Replace aperture and window if required.
Tape does not advance	a. No tension on take up reel	Check setscrew in take up reel. Check to see if manual advance possible on tape.
Tape breaking	a. High liquid content in sample gas	Genie probe and additional filtration may be required.
	b. Feed wheel not spinning freely	Dust and refuse build up between feed wheel and chassis. Requires removal and cleaning of chassis.
	c. Tape cover wheels pressing against tape.	Tape cover wheel became warped. Needs to be flattened to not contact tape when on feed wheel bolt.
	d. Trigger slide not seated properly	Ensure trigger slide is seated in groove of sample chamber
Slow Response	a. Aperture in chamber not optimized for sample stream hydrogen sulfide reading.	Removal or change of aperture type required. Contact Envent tech support for ideal setting
	b. Liquid contamination in sample tubing	Sample system requires cleaning. Refer to Cleaning procedures.
	c. Sensor block in fault	Re-zero Sensor block. Refer to Sensor Re-zero

		procedure.
Higher or Lower than expecting reading	a. Liquid contamination in sample tubing	Sample system requires cleaning. Refer to Cleaning procedures.
	b. Sample vent either blocked or frozen	Vent should be 1/2" tubing on a downward slope.
	c. Contaminants in sample chamber	Sample system requires cleaning. Refer to cleaning procedures.
Fault light indicated	a. Sensor Low fault	Re-zero Sensor block. Refer to Sensor Re-zero procedure.
	b. Sensor High fault	Re-zero Sensor block. Refer to sensor re-zero procedure.
	c. Low Tape	Sensing tape requires change. Possible low tape sensor failure.
	d. Low pressure	Pressure on outlet of regulator is lower than set point of pressure switch. ( <i>factory set to 10 psi</i> )
Sensor Fault	a. Sensor didn't zero on white tape.	Re-zero Sensor block. Refer to Sensor Re-zero procedure.
	b. Sensor Wire failure	Wire or Sensor requires replacement.

### Re-Zero Sensor Procedure

1. Put the Analyzer in bypass
2. Turn off Sample gas at flow meter
3. Press the Menu/Set button until Mtr Run displayed
4. Press Left or Right on Display move tape to a new white piece of tape
5. Remove the cover over the sensor block. Press the small pushbutton located on the lower left side next to the wire connector. The sensor block will enter a "re-zero" procedure indicated by a red led.
6. When the "re-zero" procedure is complete the green led should illuminate.
7. Initiate another motor run
8. Press the Menu/Set button until zero is displayed. Value should be between 900 & 1100 mv
9. Turn on sample gas to flow of two.
10. Take analyzer out of bypass.

### Sample System Cleaning Procedure

During startup or plant upset situations, the hydrogen sulfide analyzer may become contaminated with hydrogen sulfide scavenger solution. This may cause the analyzer to read low. This condition can be determined at calibration. The analyzer will read low and require incremental increases in the gain to maintain calibration. Please refer to factory calibration sheet for default gain factor. The scavenger solution is water soluble and therefore is relatively easy to clean.

#### Cleaning Material List.

Alconox Laboratory cleaner or equivalent residue free cleaning agent. Do not use solvents, detergents  
Fresh water.  
100% Isopropyl Alcohol. Do not use rubbing alcohol  
Large bucket to mix cleaning solution  
Rinse bottle

#### Procedure:

Mix a 1% (2-1/2 tbsp per gal.) of Alconox in warm water.

#### Sample line Tubing

Shut off flow at the sample point prior to sample system  
Flush the sample line and components with cleaning solution  
Rinse with fresh water  
Flush with isopropyl alcohol  
Dry with clean, dry instrument air or gas

#### Sample System

**Note:** Dis-assembly of the pressure regulator in the field is not advised. Consult the factory if the regulator appears contaminated

Remove filter elements from filter housings and discard  
Remove all sample system components and soak in cleaning solution  
Ensure valves are fully open when cleaning.  
Flush sample components with fresh water  
Rinse with isopropyl alcohol  
Blow dry with clean compressed air or fuel gas  
If the Tygon tubing appears discolored replace with new tubing  
Tubing on Humidifier should be replaced if it appears contaminated  
Install new filter elements into filter housings  
Re-assemble Stainless Steel Tubing to analyzer according to analyzer drawing (refer to back of manual)

Once sample system has been re-assembled. Apply calibration gas to the analyzer.

Adjust gain to indicate value from calibration certificate

Gains for streams should be +/- 2.00 from factory cal sheet or last calibration. If the reading is not within range, then the analyzer sample system may need further cleaning. Please consult factory.

#	Description	Part number
1	Trigger Slide	330042
2	Sample Chamber	330075
3	Senosr block clips	330074
4	Sensor block	330230

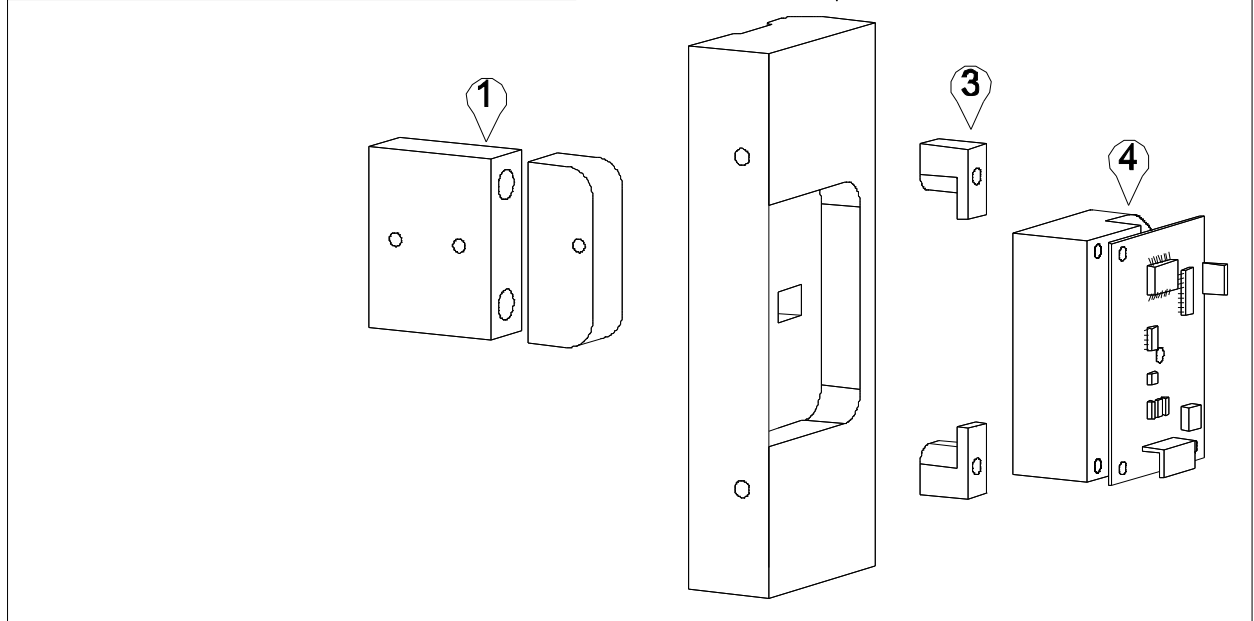

**Sample Chamber**